



**Chicago
Pneumatic**

Spare parts list

Handheld rotary hammers

CP 0009 A, F, E, CS, ES, AC

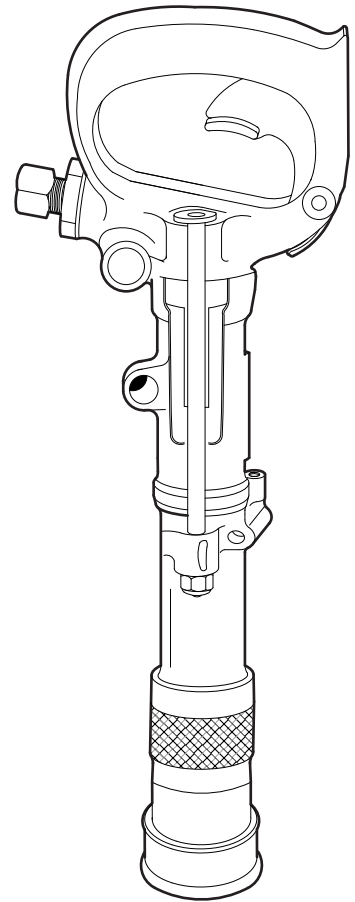

Contents

General information	5
Spare parts list	6
CP 0009 A	6
CP 0009 F	8
CP 0009 E	10
CP 0009 CS	12
CP 0009 ES	14
CP 0009 AC	16
Working tools	18
Round $\frac{3}{4}$ " x $3\frac{1}{4}$ " (19 x 95 mm).....	18
Round $\frac{9}{16}$ " x $3\frac{1}{2}$ " (14.7 x 89 mm).....	19
Round $\frac{3}{4}$ " - Hexagon $\frac{9}{16}$ " x $3\frac{1}{2}$ " (19 mm - 14.7 x 89 mm).....	19
Round 19 x 95 mm ($\frac{3}{4}$ " x $3\frac{1}{4}$ ")	20
Round 14.7 x 89 mm ($\frac{9}{16}$ " x $3\frac{1}{2}$ ")	20
Round 19 mm - Hexagon 14.7 x 89 mm ($\frac{3}{4}$ " - $\frac{9}{16}$ " x $3\frac{1}{2}$ ").....	21
Accessories	22
Hose rolls.....	22
Pre-mounted universal hoses with claw couplings.....	22
Water separator.....	23
Lubricator.....	23
CP Airolene Plus Rock Drill Oil.....	23

General information

This spare parts list applies to the following:

Description
Handheld rotary hammers CP 0009 A
Handheld rotary hammers CP 0009 F
Handheld rotary hammers CP 0009 E
Handheld rotary hammers CP 0009 CS
Handheld rotary hammers CP 0009 ES
Handheld rotary hammers CP 0009 AC

Use only authorized parts. Any damage or malfunction caused by the use of unauthorized parts is not covered by Warranty or Product Liability. Any unauthorized use or copying of the contents or any part thereof is prohibited. This applies in particular to trademarks, model denominations, part numbers, and drawings.

Instructions for use

This spare parts list contains no safety regulations and is merely intended to assist in the ordering of spare parts.

For information about operating, servicing, or repairing, the relevant Safety and operating instructions must be consulted at all costs.

Please observe the safety instructions listed in the relevant Safety and operating instructions!

Spare parts list

CP 0009 A

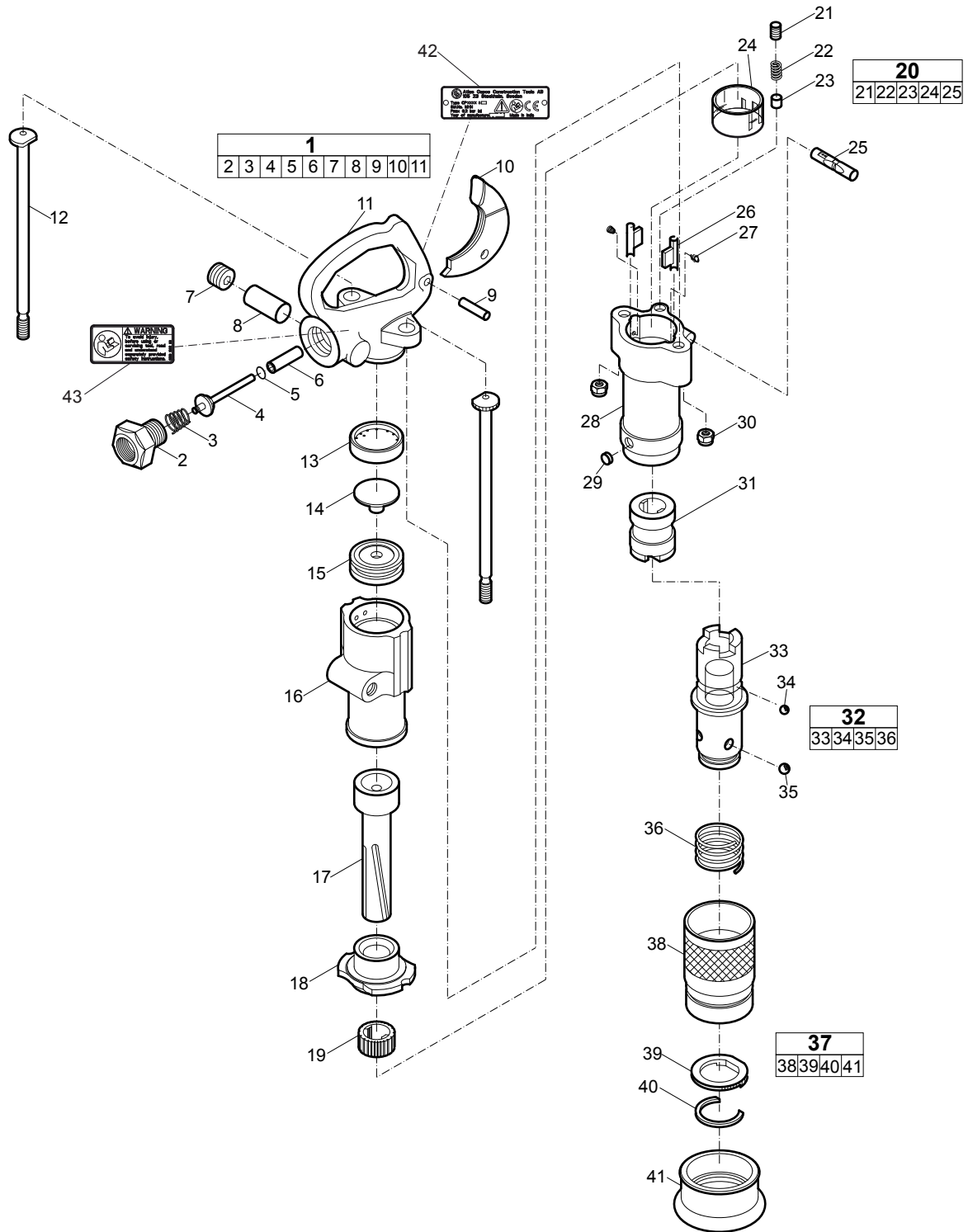

No.	Description	Remark	Quantity	Part number
1(2-11)	Handle, complete		1	R278018
2	Bushing - air inlet	3/8 in. NPTF (conical head)	1	R085893
3	Spring - throttle valve		1	R085596
4	Valve - throttle		1	R086329
5	Seat - throttle valve		1	R086098
6	Bushing - throttle valve		1	R085599
7	Plug - pipe	3/8 in.	1	C077941
8	Felt - oil chamber		1	R085895
9	Pin - throttle lever		1	A043627
10	Lever - throttle		1	F027853
11	Handle		1	-
12	Bolt - thru		2	F034249
13	Rear valve seat		1	R085896
14	Valve		1	R085897
15	Front valve seat		1	R085898
16	Cylinder		1	R085886
17	Piston		1	F816122
18	Cylinder bushing		1	R051356
19	Ratchet ring		1	F816123
20(21-25)	Rotation release, complete		1	Z8294412
21	Plug - pipe	1/16 in. NPTF	1	C102507
22	Spring - plunger		1	R051353
23	Plunger - shifter detent		1	R051352
24	Sleeve - shifter		1	F816124
25	Plunger - shifter		1	R051351
26	Rotation release, complete		1	Z8294412
27	Spring - pawl		2	R085890
28	Fronthead		1	F816120
29	Plug - ball retainer		1	F061888
30	Nut - thru bolt		2	S013073
31	Chuck sleeve		1	R085900
32(33-36)	Round chuck, complete		1	Z8366412
33	Chuck		1	-
34	Chuck retainer ball, complete	Only available as kit with 17 balls	17	Z8767412
35	Ball - steel, complete	Ø3/16 in. (7.9 mm). Only available as kit with 4 balls	4	Z8768412
36	Spring - sleeve retainer		1	R086605
37(38-41)	Retainer sleeve, complete		1	Z8375412
38	Retainer		1	-
39	Retainer plate		1	F826683
40	Retainer ring		1	F826893
41	Dust excluder		1	F815343
42	Data plate		1	-
43	Safety label		1	3310 1602 00

CP 0009 F

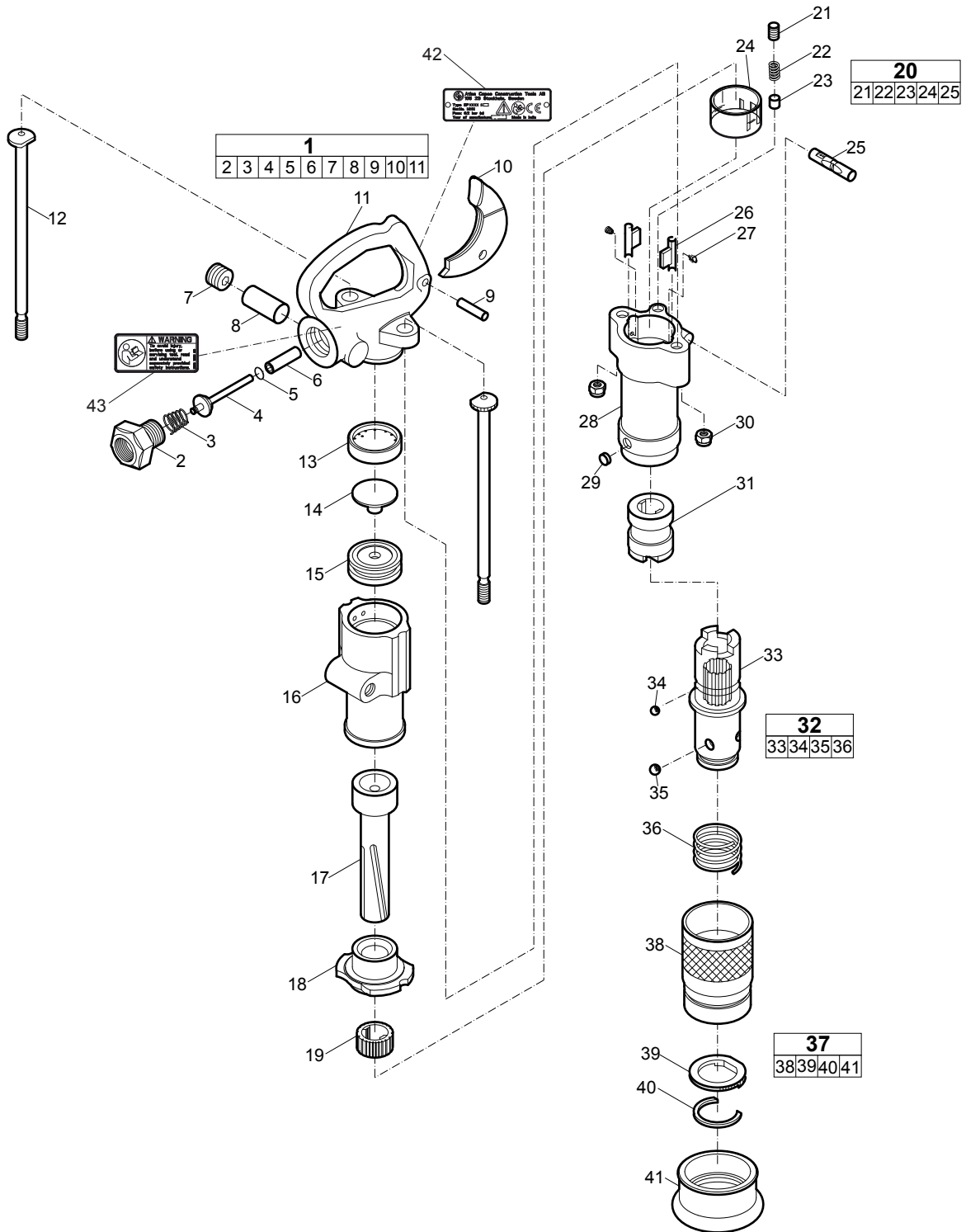

No.	Description	Remark	Quantity	Part number
1(2-11)	Handle, complete		1	R278018
2	Bushing - air inlet	3/8 in. NPTF (conical head)	1	R085893
3	Spring - throttle valve		1	R085596
4	Valve - throttle		1	R086329
5	Seat - throttle valve		1	R086098
6	Bushing - throttle valve		1	R085599
7	Plug - pipe	3/8 in.	1	C077941
8	Felt - oil chamber		1	R085895
9	Pin - throttle lever		1	A043627
10	Lever - throttle		1	F027853
11	Handle		1	-
12	Bolt - thru		2	F034249
13	Rear valve seat		1	R085896
14	Valve		1	R085897
15	Front valve seat		1	R085898
16	Cylinder		1	R085886
17	Piston		1	F816122
18	Cylinder bushing		1	R051356
19	Ratchet ring		1	F816123
20(21-25)	Rotation release, complete		1	Z8294412
21	Plug - pipe	1/16 in. NPTF	1	C102507
22	Spring - plunger		1	R051353
23	Plunger - shifter detent		1	R051352
24	Sleeve - shifter		1	F816124
25	Plunger - shifter		1	R051351
26	Pawl		2	R051355
27	Spring - pawl		2	R085890
28	Fronthead		1	F816120
29	Plug - ball retainer		1	F061888
30	Nut - thru bolt		2	S013073
31	Chuck sleeve		1	R085900
32(33-36)	Spline chuck, complete		1	Z8369412
33	Chuck sleeve		1	R085900
34	Chuck retainer ball, complete	Only available as kit with 17 balls	17	Z8767412
35	Ball - steel, complete	Ø3/16 in. (7.9 mm). Only available as kit with 4 balls	4	Z8768412
36	Spring - sleeve retainer		1	R086605
37(38-41)	Retainer sleeve, complete		1	Z8375412
38	Retainer		1	-
39	Retainer plate		1	F826683
40	Retainer ring		1	F826893
41	Dust excluder		1	F815343
42	Data plate		1	-
43	Safety label		1	3310 1602 00

CP 0009 E

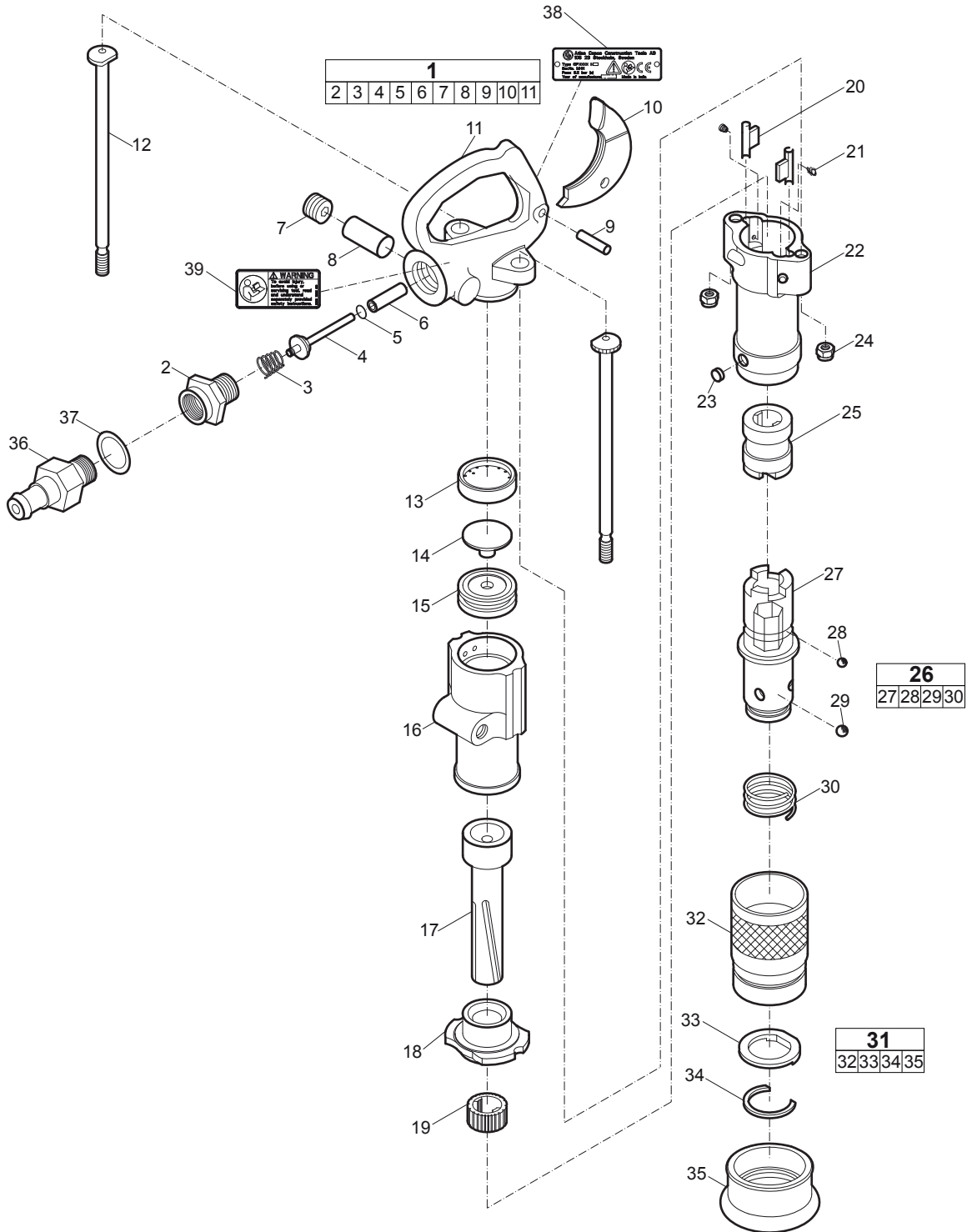

No.	Description	Remark	Quantity	Part number
1(2-11)	Handle, complete		1	F034496
2	Bushing - air inlet	3/8 in. BSP (collared head)	1	F064697
3	Spring - throttle valve		1	R085596
4	Valve - throttle		1	R086329
5	O-ring	special	1	R086098
6	Bushing - throttle valve		1	R085599
7	Oil plug		1	C077941
8	Felt - oil chamber		1	R085895
9	Pin - throttle lever		1	A043627
10	Lever - throttle		1	F027853
11	Handle		1	-
12	Bolt - thru		2	F034249
13	Rear valve seat		1	R085896
14	Valve		1	R085897
15	Front valve seat		1	R085898
16	Cylinder		1	R085886
17	Piston		1	F816122
18	Cylinder bushing		1	R085887
19	Ratchet ring		1	F816123
20	Pawl		2	F034066
21	Spring - pawl		2	R085890
22	Fronthead		1	R136592
23	Plug - ball retainer		1	F061888
24	Nut - thru bolt		2	S013073
25	Chuck sleeve		1	R085900
26(27-30)	Hexagon chuck, complete		1	Z8368412
27	Chuck		1	-
28	Chuck retainer ball, complete	Only available as kit with 17 balls	17	Z8767412
29	Ball - steel, complete	Ø5/16 in. (7.9 mm). Only available as kit with 4 balls	4	Z8768412
30	Spring - sleeve retainer		1	F816162
31(32-35)	Retainer sleeve, complete		1	Z8375412
32	Retainer		1	-
33	Retainer plate		1	F826683
34	Retainer ring		1	F826893
35	Dust excluder		1	F815343
36	Hose tail		1	F064695
37	Gasket		1	F064696
38	Data plate		1	-
39	Safety label		1	3310 1602 00

CP 0009 CS

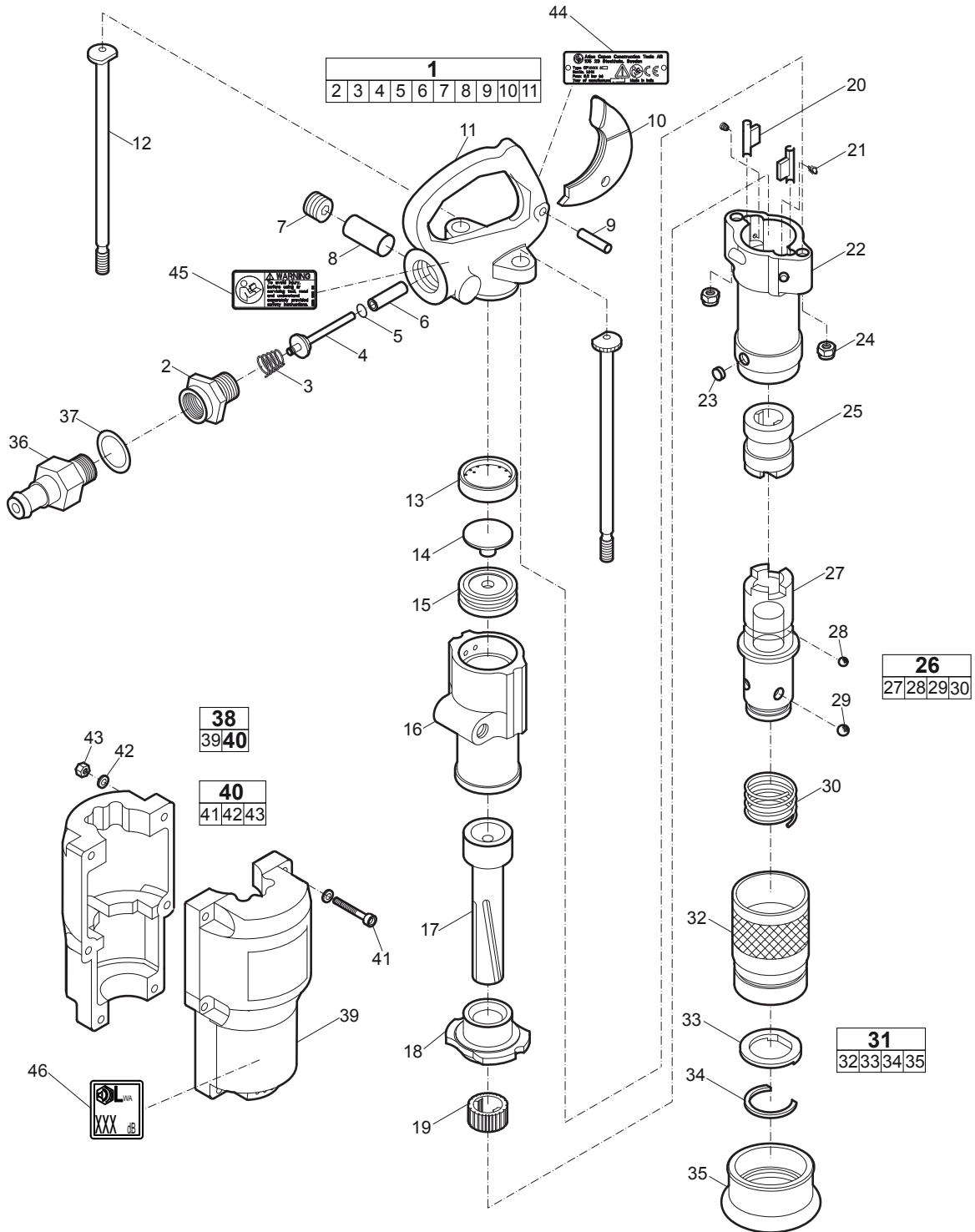

No.	Description	Remark	Quantity	Part number
1(2-11)	Handle, complete		1	F034496
2	Bushing - air inlet	3/8 in. BSP (collared head)	1	F064697
3	Spring - throttle valve		1	R085596
4	Valve - throttle		1	R086329
5	O-ring	special	1	R086098
6	Bushing - throttle valve		1	R085599
7	Oil plug		1	C077941
8	Felt - oil chamber		1	R085895
9	Pin - throttle lever		1	A043627
10	Lever - throttle		1	F027853
11	Handle		1	-
12	Bolt - thru		2	F034249
13	Rear valve seat		1	R085896
14	Valve		1	R085897
15	Front valve seat		1	R085898
16	Cylinder		1	R085886
17	Piston		1	F816122
18	Cylinder bushing		1	R085887
19	Ratchet ring		1	F816123
20	Pawl		2	F034066
21	Spring - pawl		2	R085890
22	Fronthead		1	R136592
23	Plug - ball retainer		1	F061888
24	Nut - thru bolt		2	S013073
25	Chuck sleeve		1	R085900
26(27-30)	Round chuck, complete		1	Z8366412
27	Chuck		1	-
28	Chuck retainer ball, complete	Only available as kit with 17 balls	17	Z8767412
29	Ball - steel, complete	Ø5/16 in. (7.9 mm). Only available as kit with 4 balls	4	Z8768412
30	Spring - sleeve retainer		1	R086605
31(32-35)	Retainer sleeve, complete		1	Z8375412
32	Retainer		1	-
33	Retainer plate		1	F826683
34	Retainer ring		1	F826893
35	Dust excluder		1	F815343
36	Hose tail		1	F064695
37	Gasket		1	F064696
38(39,40)	Muffler, complete		1	F826972
39	Muffler		2	-
40(41-43)	Screw, complete		1	Z3631412
41	Capscrew		6	-
42	Washer		12	-
43	Nut		6	-
44	Data plate		1	-
45	Safety label		1	3310 1602 00
46	Noise level label		1	-

CP 0009 ES

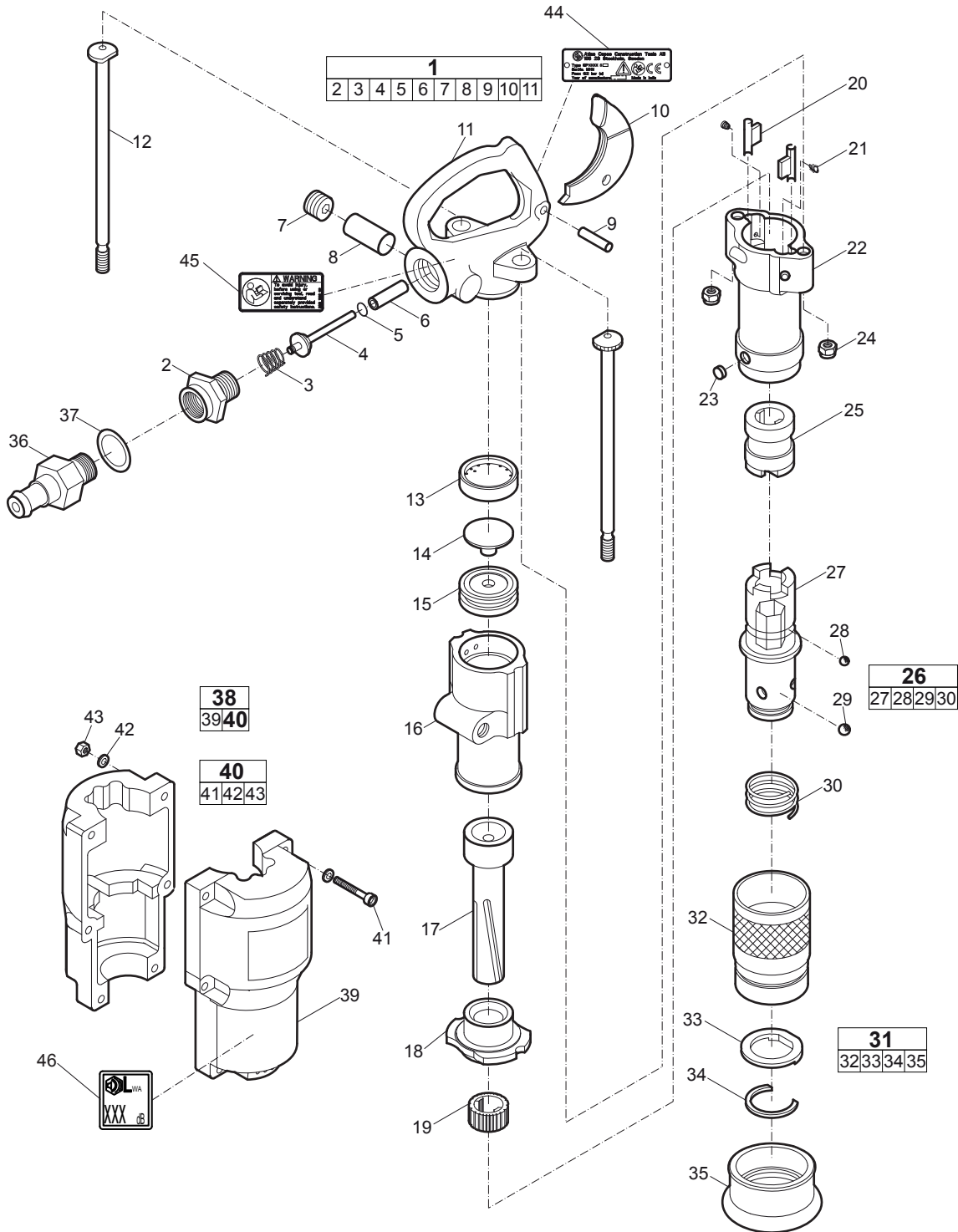

No.	Description	Remark	Quantity	Part number
1(2-11)	Handle, complete		1	F034496
2	Bushing - air inlet	3/8 in. BSP (collared head)	1	F064697
3	Spring - throttle valve		1	R085596
4	Valve - throttle		1	R086329
5	O-ring	special	1	R086098
6	Bushing - throttle valve		1	R085599
7	Oil plug		1	C077941
8	Felt - oil chamber		1	R085895
9	Pin - throttle lever		1	A043627
10	Lever - throttle		1	F027853
11	Handle		1	-
12	Bolt - thru		2	F034249
13	Rear valve seat		1	R085896
14	Valve		1	R085897
15	Front valve seat		1	R085898
16	Cylinder		1	R085886
17	Piston		1	F816122
18	Cylinder bushing		1	R085887
19	Ratchet ring		1	F816123
20	Pawl		2	F034066
21	Spring - pawl		2	R085890
22	Fronthead		1	R136592
23	Plug - ball retainer		1	F061888
24	Nut - thru bolt		2	S013073
25	Chuck sleeve		1	R085900
26(27-30)	Hexagon chuck, complete		1	Z8368412
27	Chuck		1	-
28	Chuck retainer ball, complete	Only available as kit with 17 balls	17	Z8767412
29	Ball - steel, complete	Ø5/16 in. (7.9 mm). Only available as kit with 4 balls	4	Z8768412
30	Spring - sleeve retainer		1	F816162
31(32-35)	Retainer sleeve, complete		1	Z8375412
32	Retainer		1	-
33	Retainer plate		1	F826683
34	Retainer ring		1	F826893
35	Dust excluder		1	F815343
36	Hose tail		1	F064695
37	Gasket		1	F064696
38(39,40)	Muffler, complete		1	F826972
39	Muffler		2	-
40(41-43)	Screw, complete		1	Z3631412
41	Capscrew		6	-
42	Washer		12	-
43	Nut		6	-
44	Data plate		1	-
45	Safety label		1	3310 1602 00
46	Noise level label		1	-

CP 0009 AC

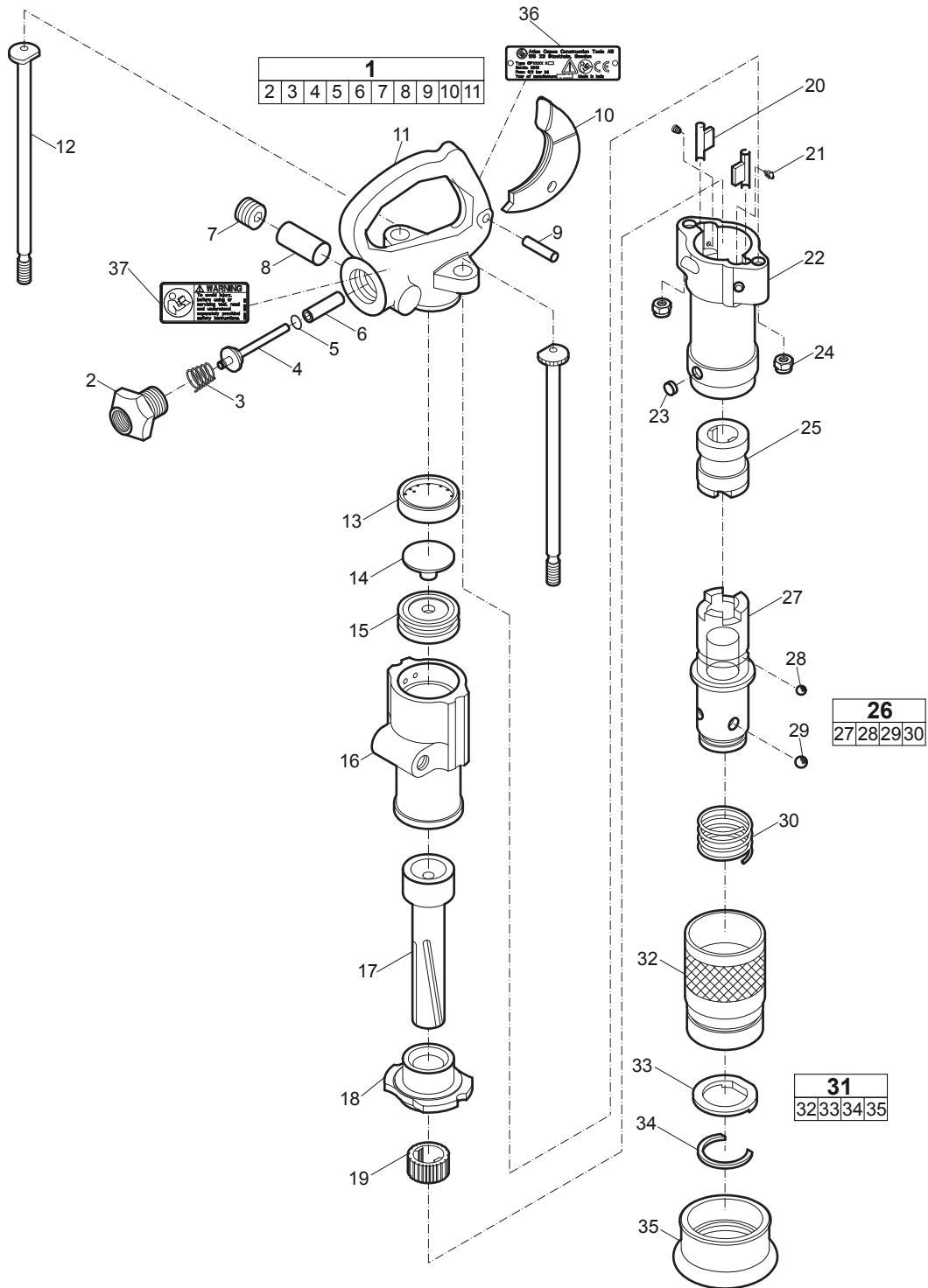

No.	Description	Remark	Quantity	Part number
1(2-11)	Handle, complete		1	R278018
2	Bushing - air inlet	3/8 in. NPTF (conical head)	1	R085893
3	Spring - throttle valve		1	R085596
4	Valve - throttle		1	R086329
5	O-ring	special	1	R086098
6	Bushing - throttle valve		1	R085599
7	Oil plug		1	C077941
8	Felt - oil chamber		1	R085895
9	Pin - throttle lever		1	A043627
10	Lever - throttle		1	F027853
11	Handle		1	-
12	Bolt - thru		2	F034249
13	Rear valve seat		1	R085896
14	Valve		1	R085897
15	Front valve seat		1	R085898
16	Cylinder		1	R085886
17	Piston		1	F816122
18	Cylinder bushing		1	R085887
19	Ratchet ring		1	F816123
20	Pawl		2	F034066
21	Spring - pawl		2	R085890
22	Fronthead		1	R136592
23	Plug - ball retainer		1	F061888
24	Nut - thru bolt		2	S013073
25	Chuck sleeve		1	R085900
26(27-30)	Round chuck, complete		1	Z8366412
27	Chuck		1	-
28	Chuck retainer ball, complete	Only available as kit with 17 balls	17	Z8767412
29	Ball - steel, complete	Ø5/16 in. (7.9 mm). Only available as kit with 4 balls	4	Z8768412
30	Spring - sleeve retainer		1	R086605
31(32-35)	Retainer sleeve, complete		1	Z8375412
32	Retainer		1	-
33	Retainer plate		1	F826683
34	Retainer ring		1	F826893
35	Dust excluder		1	F815343
36	Data plate		1	-
37	Safety label		1	3310 1602 00

Working tools

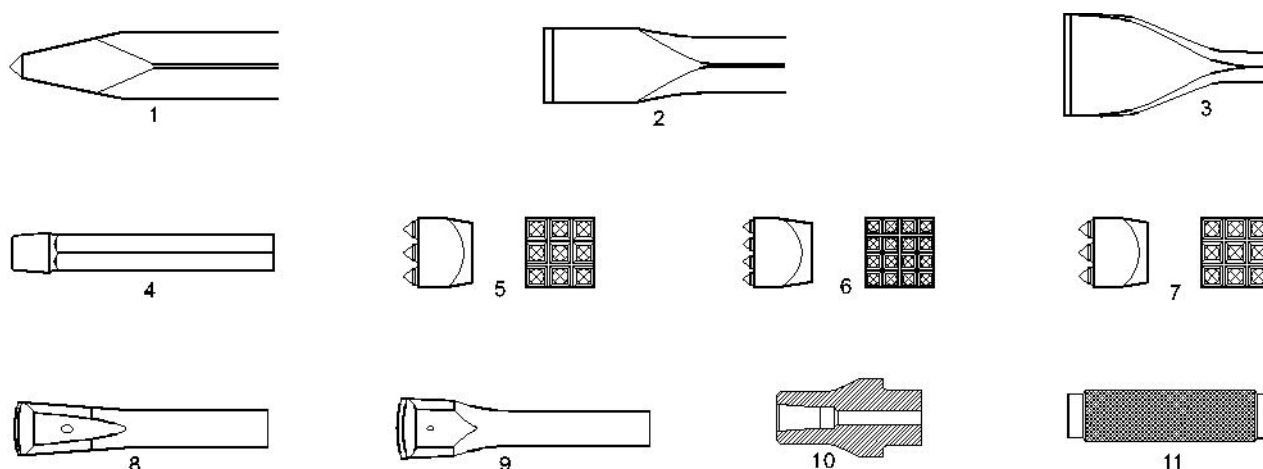

Round $3/4'' \times 3 1/4''$ (19 x 95 mm)

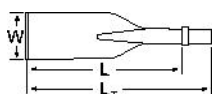

No.	Description	W (in.)	L (in.)	L _T (in.)	Wt (lb)	Part number
1	Moil point	-	6	10	1.5	3083 4160 00
		-	11	15	2.2	3083 3261 00
2	Narrow chisel	-	6	10	1.5	3083 4161 00
		-	11	15	2.2	3083 3262 00
3	Wide chisel	3	6	10	1.8	3083 4165 00
4	Shaft for bush hammer	-	5	9	1.3	3083 4162 00
5	Bush hammer TC head	1½	-	-	1.1	3083 3226 00
6	Bush hammer TC head	1½	-	-	1.1	3083 3227 00
7	Bush hammer steel head	1¼	-	-	0.4	3083 4163 00

No.	Description	Drill depth (in.)	Bit diameter (in.)	L _T (in.)	Wt (lb)	Part number
8	Plug hole drill	8	Ø½	13	0.9	3083 4150 00
8	Plug hole drill	10½	Ø½	15½	1.1	3083 4150 10
8	Plug hole drill	8	Ø⅝	13	0.9	3083 4151 00
8	Plug hole drill	12	Ø⅝	17	1.1	3083 4151 10
8	Plug hole drill	18	Ø⅝	23	1.8	3083 4151 20
8	Plug hole drill	8	Ø¾	13	1.3	3083 4152 00
8	Plug hole drill	12	Ø¾	17	1.5	3083 4152 10
8	Plug hole drill	18	Ø¾	23	2.0	3083 4152 20
8	Plug hole drill	8	Ø⅞	13	1.5	3083 4153 00
8	Plug hole drill	12	Ø⅞	17	2.0	3083 4153 10
8	Plug hole drill	18	Ø⅞	23	2.6	3083 4153 20
8	Plug hole drill	8	Ø1	13	1.5	3083 4154 00
8	Plug hole drill	12	Ø1	17	2.2	3083 4154 10

No.	Description	Drill depth (in.)	Bit diameter (in.)	L _T (in.)	Wt (lb)	Part number
8	Plug hole drill	18	Ø1	23	2.9	3083 4154 20
8	Plug hole drill	8	Ø1½	13	1.8	3083 4155 00
8	Plug hole drill	12	Ø1½	17	2.2	3083 4155 10
8	Plug hole drill	18	Ø1½	23	2.9	3083 4155 20
8	Plug hole drill	8	Ø1¼	13	2.0	3083 4156 00
8	Plug hole drill	12	Ø1¼	17	2.2	3083 4156 10
8	Plug hole drill	18	Ø1¼	23	2.9	3083 4156 20

Round 9/16" x 3 1/2" (14.7 x 89 mm)

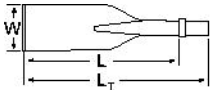

No.	Description	W (in.)	L (in.)	L _T (in.)	Wt (lb)	Part number
1	Moil point	-	8¼	12	1.3	3083 3263 00
2	Narrow chisel	-	8¼	12	1.3	3083 3264 00

Round 3/4" - Hexagon 9/16" x 3 1/2" (19 mm - 14.7 x 89 mm)

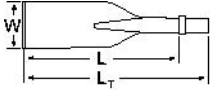

No.	Description	Remark	Drill depth (in.)	Bit diameter (in.)	L _T (in.)	Wt (lb)	Part number
8	Plug hole drill	Use with shank adapter	3	Ø5/16	4¼	0.04	0701 0808 00
			4	Ø13/32	5	0.09	0701 1010 00
			4¾	Ø½	6	0.18	0701 1212 00
9	Plug hole drill		6	Ø5/8	10	0.9	0700 1416 32
			9	Ø¾	13	1.1	0700 2019 32
			9	Ø7/8	13	1.3	0700 2022 32
			9	Ø1	13	1.5	0700 2025 32
			13	Ø1¼	17	2.2	0700 3032 32
			13	Ø1½	17	3.1	0700 3038 32
10	Shank adapter	For 0.31, 0.39 and 0.47 in. drills	-	-	5	0.4	0701 1001 32
11	Knock-out block	Use with shank adapter For 0.31, 0.39 and 0.47 in. drills	-	-	-	1.8	3085 0210 00

Round 19 x 95 mm (3/4" x 3 1/4")

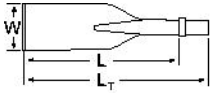

No.	Description	W (mm)	L (mm)	L _T (mm)	Wt (kg)	Part number
1	Moil point	-	150	255	0.7	3083 4160 00
		-	275	380	1.0	3083 3261 00
2	Narrow chisel	-	150	255	0.7	3083 4161 00
		-	275	380	1.0	3083 3262 00
3	Wide chisel	75	150	255	0.8	3083 4165 00
4	Shaft for bush hammer	-	125	230	0.6	3083 4162 00
5	Bush hammer TC head	40	-	-	0.5	3083 3226 00
6	Bush hammer TC head	40	-	-	0.5	3083 3227 00
7	Bush hammer steel head	32	-	-	0.2	3083 4163 00

No.	Description	Drill depth (mm)	Bit diameter (mm)	L _T (mm)	Wt (kg)	Part number
8	Plug hole drill	200	Ø13	330	0.4	3083 4150 00
8	Plug hole drill	265	Ø13	395	0.5	3083 4150 10
8	Plug hole drill	200	Ø16	330	0.5	3083 4151 00
8	Plug hole drill	300	Ø16	430	0.6	3083 4151 10
8	Plug hole drill	450	Ø16	580	0.8	3083 4151 20
8	Plug hole drill	200	Ø19	330	0.6	3083 4152 00
8	Plug hole drill	300	Ø19	430	0.7	3083 4152 10
8	Plug hole drill	450	Ø19	580	0.9	3083 4152 20
8	Plug hole drill	200	Ø22	330	0.7	3083 4153 00
8	Plug hole drill	300	Ø22	430	0.9	3083 4153 10
8	Plug hole drill	450	Ø22	580	1.2	3083 4153 20
8	Plug hole drill	200	Ø25	330	0.7	3083 4154 00
8	Plug hole drill	300	Ø25	430	1.0	3083 4154 10
8	Plug hole drill	450	Ø25	580	1.3	3083 4154 20
8	Plug hole drill	200	Ø28	330	0.8	3083 4155 00
8	Plug hole drill	300	Ø28	430	1.0	3083 4155 10
8	Plug hole drill	450	Ø28	580	1.3	3083 4155 20
8	Plug hole drill	200	Ø32	330	0.9	3083 4156 00
8	Plug hole drill	300	Ø32	430	1.0	3083 4156 10
8	Plug hole drill	450	Ø32	580	1.3	3083 4156 20

Round 14.7 x 89 mm (9/16" x 3 1/2")

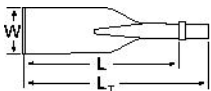

No.	Description	W (mm)	L (mm)	L _T (mm)	Wt (kg)	Part number
1	Moil point	-	210	300	0.6	3083 3263 00
2	Narrow chisel	-	210	300	0.6	3083 3264 00

Round 19 mm - Hexagon 14.7 x 89 mm ($\frac{3}{4}$ " - $\frac{9}{16}$ " x $3\frac{1}{2}$ ")

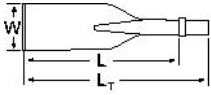

No.	Description	Remark	Drill depth (mm)	Bit diameter (mm)	L _T (mm)	Wt (kg)	Part number
8	Plug hole drill	Use with shank adapter	80	Ø8	110	0.02	0701 0808 00
			100	Ø10	130	0.04	0701 1010 00
			120	Ø12	150	0.08	0701 1212 00
9	Plug hole drill		150	Ø16	250	0.4	0700 1416 32
			230	Ø19	330	0.5	0700 2019 32
			230	Ø22	330	0.6	0700 2022 32
			230	Ø25	330	0.7	0700 2025 32
			330	Ø32	430	1.0	0700 3032 32
			330	Ø38	430	1.4	0700 3038 32
10	Shank adapter	For 8, 10 and 12 mm drills	-	-	125	0.2	0701 1001 32
11	Knock-out block	Use with shank adapter For 8, 10 and 12 mm drills	-	-	-	0.8	3085 0210 00

Accessories

Hose rolls

Metric

Description	Inner diameter (mm)	Thickness (mm)	Maximum working pressure (bar)	Length of roll (m)	Weight (kg)	Part number
Red-X hose roll	19	2.0	20	60	11	8900 0050 10
Red-X hose roll	19	2.0	20	100	18	8900 0050 11
Red-X hose roll	19	2.0	20	200	36	8900 0050 12
Red-X hose roll	25	2.5	20	60	15	8900 0050 20
Red-X hose roll	25	2.5	20	100	25	8900 0050 21
Red-X hose roll	25	2.5	20	200	50	8900 0050 22

Imperial

Description	Inner diameter (in.)	Thickness (in.)	Maximum working pressure (psi)	Length of roll (ft)	Weight (lb)	Part number
Red-X hose roll	$\frac{3}{4}$	$\frac{5}{64}$	290	195	24.3	8900 0050 10
Red-X hose roll	$\frac{3}{4}$	$\frac{5}{64}$	290	325	39.7	8900 0050 11
Red-X hose roll	$\frac{3}{4}$	$\frac{5}{64}$	290	650	79.4	8900 0050 12
Red-X hose roll	1	$\frac{3}{32}$	290	195	33.1	8900 0050 20
Red-X hose roll	1	$\frac{3}{32}$	290	325	55.1	8900 0050 21
Red-X hose roll	1	$\frac{3}{32}$	290	650	110.2	8900 0050 22

Pre-mounted universal hoses with claw couplings

Metric

Description	Inner diameter (mm)	Thickness (mm)	Maximum working pressure (bar)	Length of roll (m)	Weight (kg)	Part number
Red-X universal hose	19	2.0	20	20	4.5	8900 0050 09
Red-X universal hose	25	2.5	20	20	6.0	8900 0050 23

Imperial

Description	Inner diameter (in.)	Thickness (in.)	Maximum working pressure (psi)	Length of roll (ft)	Weight (lb)	Part number
Red-X universal hose	$\frac{3}{4}$	$\frac{5}{64}$	290	50	8.8	8900 0050 08
Red-X universal hose	1	$\frac{3}{32}$	290	50	11.0	8900 0050 24

Water separator

Metric

Description	Hose connection (mm)	Air flow (l/s)	Weight (kg)	Part number
Water separator (¾" BSP)	20	61	0.8	8900 0050 00

Imperial

Description	Hose connection (in.)	Air flow (foot ³ /min)	Weight (lb)	Part number
Water separator (¾" NPT)	¾	130	1.8	8900 0050 01

Lubricator

Metric

Description	Hose connection (mm)	Air flow (l/s)	Oil volume (l)	Weight (kg)	Part number
Lubricator 1300 (1" BSP)	25	15-140	1.3	3	8900 0050 02

Imperial

Description	Hose connection (in.)	Air flow (foot ³ /min)	Oil volume (US gallon)	Weight (lb)	Part number
Lubricator 43 (1" NPT)	1	32-300	0.34	6.6	8900 0050 07

CP Airolene Plus Rock Drill Oil

Metric

Description	Oil volume (l)	Part number
4 l container	4	8099 0201 03
4 x 4 l container	16	8099 0201 85

Imperial

Description	Oil volume (US gallon)	Part number
1.06 US gallon container	1.06	8099 0201 03
4 x 1.06 US gallon container	4.24	8099 0201 85



2010-04 | No. 9800 0515 01

© Copyright Atlas Copco Construction Tools AB | STOCKHOLM • SWEDEN